

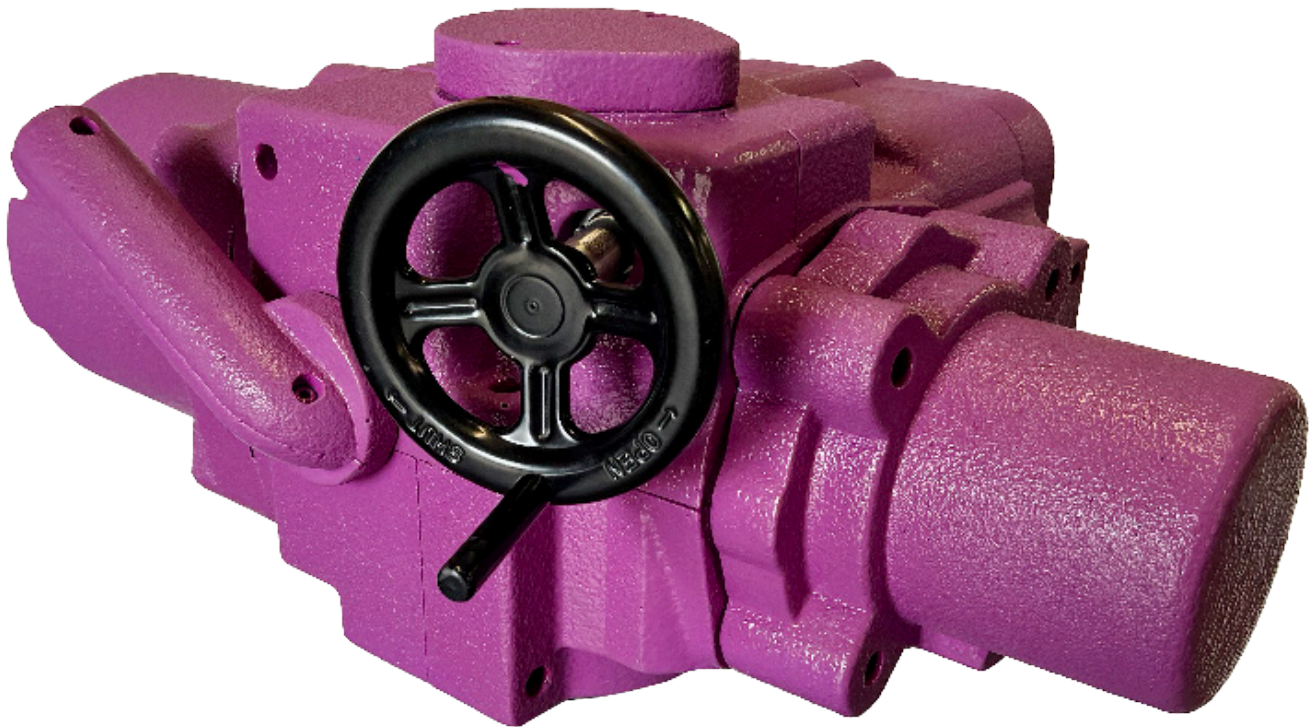

Field or Factory Installable **K-MASS**<sup>®</sup> Intumescent  
Epoxy Covers for New or Installed Actuators



**K-MASS *FI***  
INSTALLATION MANUAL

**ROTORK IQ MK3 SIZE 1**  
SIDE HANDWHEEL ACTUATORS

# ROTORK IQ MK3 Size 1

## Side Handwheel

PART NUMBERS			
Item	Description	Part Number	Qty
	<b>K-MASS FI Kit for IQ MK3 Size 1</b>	FRIQ1S-2000	1
1	Handwheel Shaft Extension	FRIQ1S-2401	1
2	Handwheel Split Pin	FRIQ1S-2402	1
3	Top Gearcase Cover - Declutch/ Handwheel Side	FRIQ1S-2100	1
4	Top Gearcase Cover - Terminal Side	FRIQ1S-2101	1
5	Motor Cover	FRIQ1S-2701	1
6	Lower Gearcase Cover - Motor Side	FRIQ1S-2102	1
7	Lower Gearcase Cover - Control Cover Side	FRIQ1S-2103	1
8	Extended Knob Shaft	FRIQ1S-2403	2
9	K-MASS Knob Spacer - Open/ Closed	FRIQ1S-2405	1
10	K-MASS Knob Spacer - Local/ Stop/ Remote	FRIQ1S-2408	1
11	New Knob - Open/ Closed	FRIQ1S-2406	1
12	New Knob - Local/ Stop/ Remote	FRIQ1S-2409	1
13	Spare "C" Clip	FRIQ1S-2407	1
14	Control Cover	FRIQ1S-2702	1
15	Terminal Cover	FRIQ1S-2703	1
16	Top Cover - Open	FRIQ1S-2704	1
17	Top Cover - Closed	FRIQ1S-2705	1
18	Single Conduit Cover (Open)	FRIQ1S-2500	1
19	Single Conduit Cover (Closed)	FRIQ1S-2501	1
20	Triple Conduit Cover	KMCP1	1
21	Declutch Lever Cover	FRIQ1S-2503	1
	3M Fire Barrier Caulk (Tube)	FI-0001	1
	Loctite Blue Thread Locker	FI-0002	1
	Box Primary/ Spare Fasteners	FRIQ1S-2003	1
	USB Drive (Installation Manual)	FRIQ1S-2004	1
	Installation Manual	FRIQ1S-2005	1



# ROTORK IQ MK3 Size 1

## Side Handwheel

### TOOLS and HARDWARE REQUIRED

ITEM	QTY
5 mm Hex-Key Wrench	1
6 mm Hex-Key Wrench	1
Torx T-30 Tamper Resistant Wrench (included) - <i>to remove knob lockout tab</i>	1
1/8" Flat Screwdriver - <i>to remove small "C" Clip</i>	1
1/8" Drift Punch - <i>to remove and install knob shafts</i>	1
3/16" Drift Punch - <i>to remove and install roll pin in the handwheel</i>	1

### FASTENERS and PARTS INCLUDED WITH KIT

SOCKET HEAD CAP SCREWS	
SIZE	QTY
M6-20	2
M6-30	4
M6-60	1
M8-30	8
M8-40	12

HANDWHEEL EXTENSION PARTS	
SIZE	QTY
Handwheel Shaft Extension	1
Split Pin 6mm x 25mm	1

### KNOB PARTS INCLUDED WITH KIT

ITEM	QTY
Extended Knob Shaft and "C" Clips	2
Extended Knob Lock-Out Bolt (M6 x 60) and Washers 6mm Flat Washers (6mm)	2
OEM Plastic Knob	2
K-MASS Knob Spacers	2

# ROTORK IQ MK3 Size 1

## Side Handwheel

Modular Intumescent Epoxy Fireproofing that can be installed in about 30 minutes in the factory or in the field.

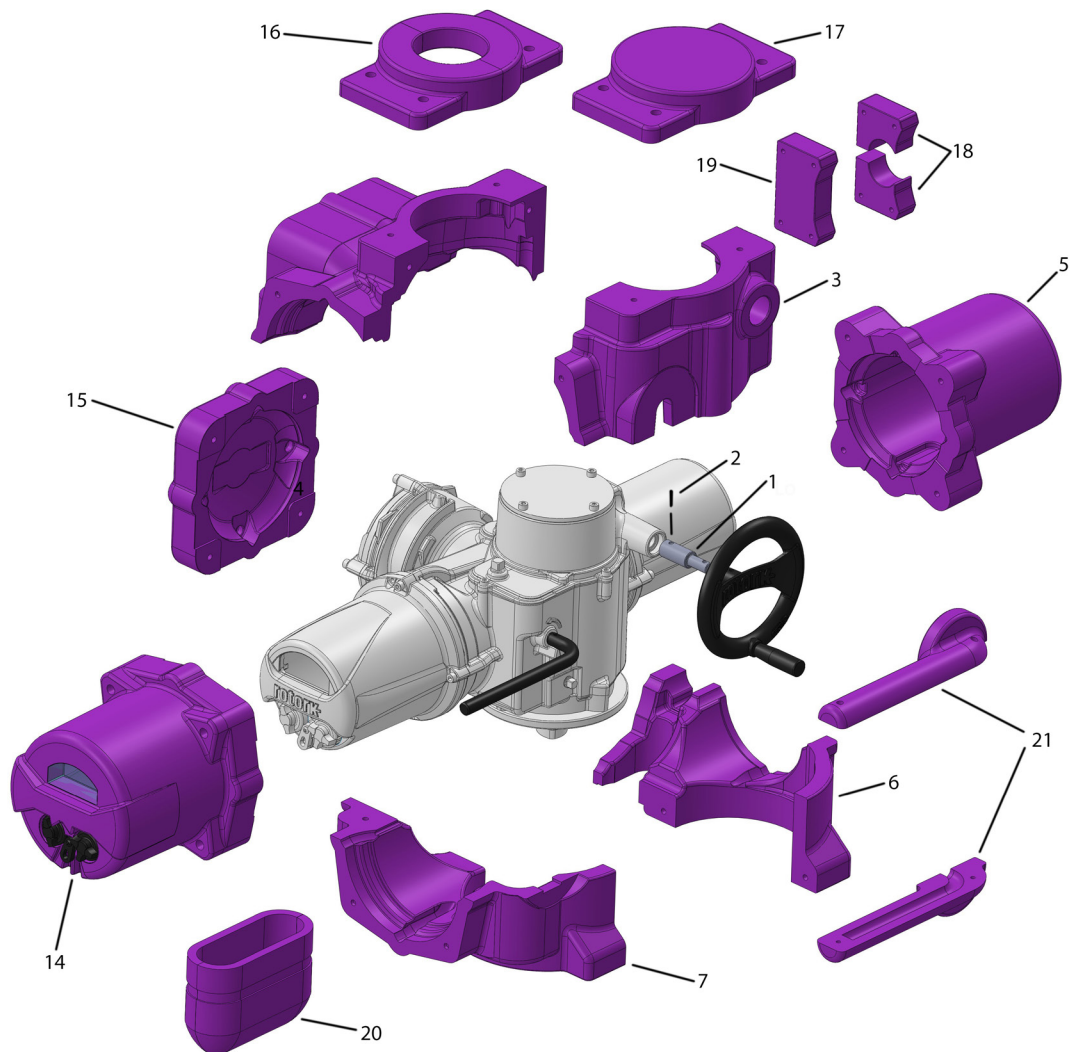

# ROTORK IQ MK3 Size 1

## Side Handwheel

### K-MASS Knob Spacers and Knobs

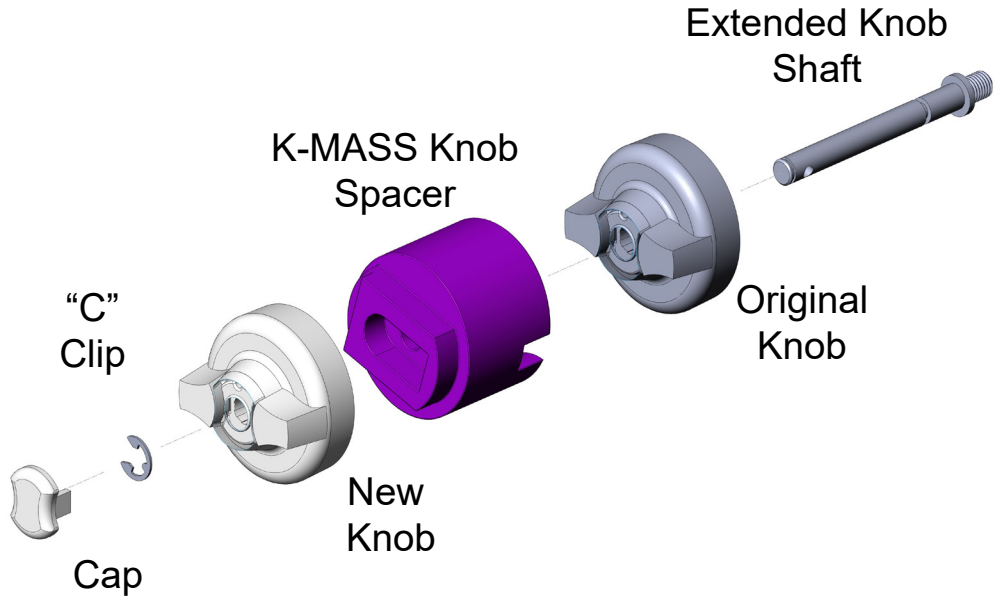

### New Lockout Tab Assembly

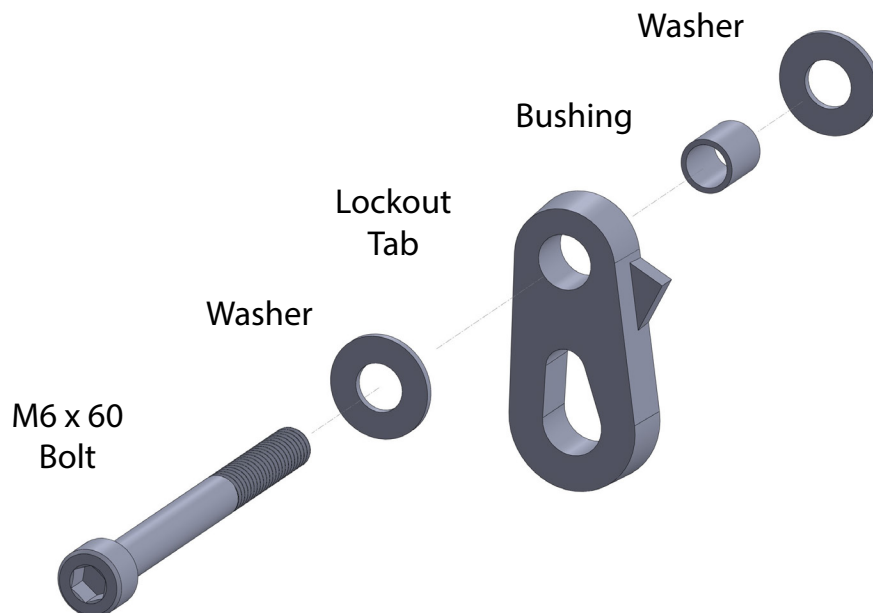

# Rotork IQ MK3 Size 1

## Side Handwheel Actuator

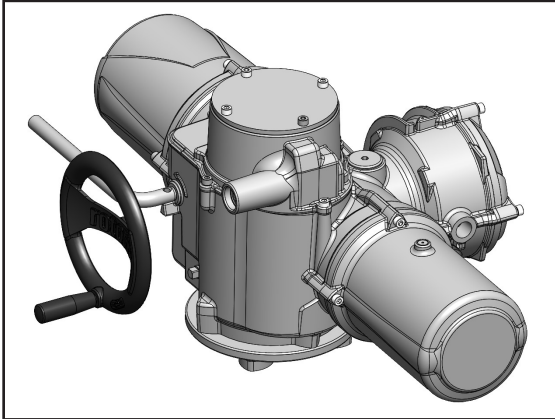

### Step 1

Remove roll pin in the handwheel and remove handwheel.

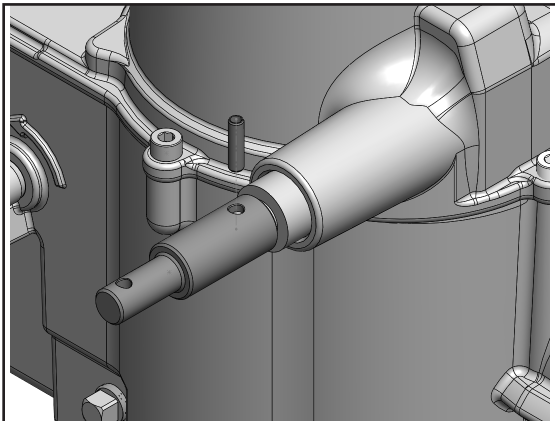

### Step 2

Install Handwheel Shaft Extension (included FRIQ1S-1401) using Roll Pin (FRIQ1S-1402 included).

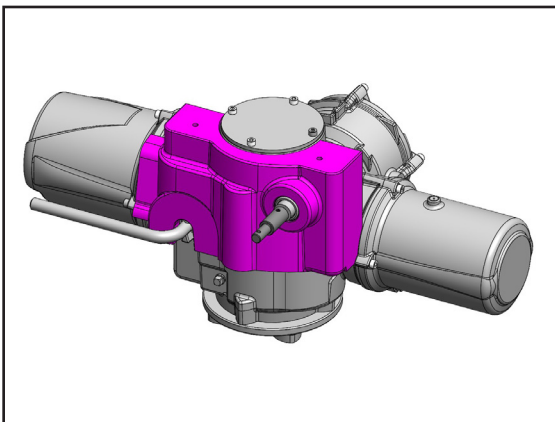

### Step 3

Fit top Handwheel/ declutch lever side Gearcase Cover (FRIQ1S-1100).

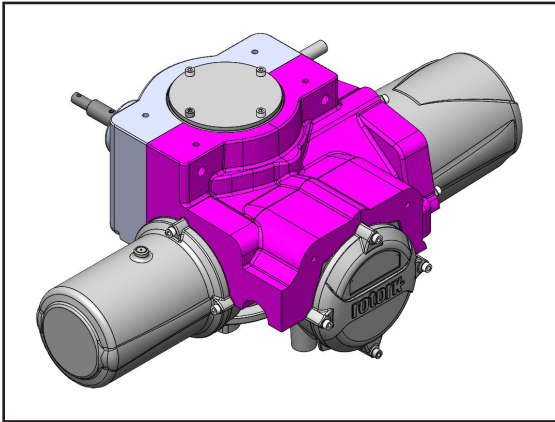

### **Step 4**

Attach the terminal side of the Top Gearcase Cover (FRIQ1S-1101) next to motor with (2) - M8 x 40 socket head cap screws.

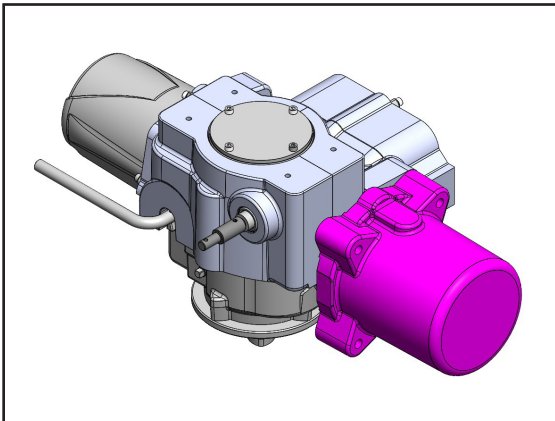

### **Step 5**

Fit Motor Cover (FRIQ1S-1701) and loosely bolt to upper Gearcase covers with (2) - M8 x 40 socket head cap screws.

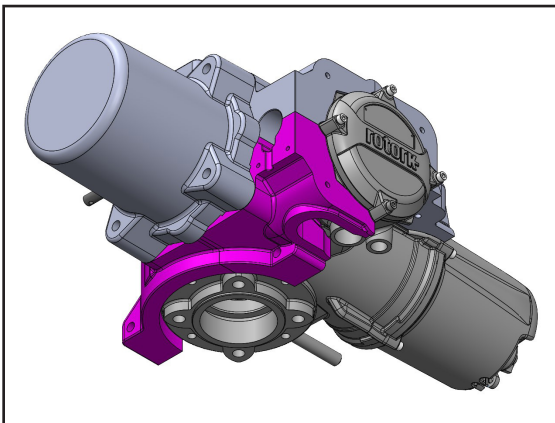

### **Step 6**

Fit the motor side Lower Gearcase Cover (FRIQ1S-1102) and loosely bolt to Motor Cover using (2) - M8 x 40 socket head cap screws.

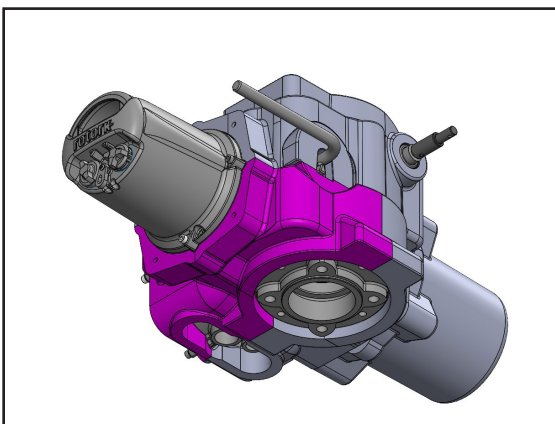

### **Step 7**

Fit the lower electronics side Gearcase Cover (FRIQ1S-1103) and loosely bolt to the motor side Gearcase Cover using (2) - M8 x 40 socket head cap screws.

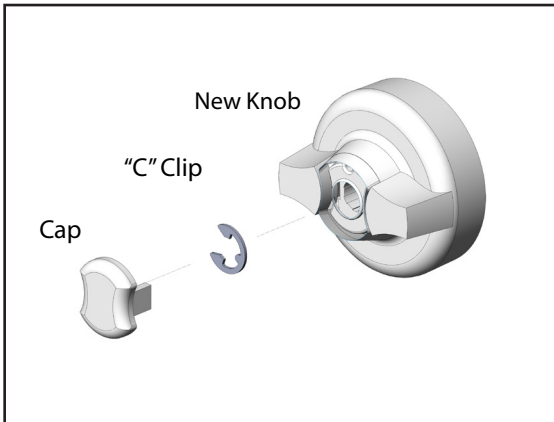

## Step 8

Remove center caps from existing plastic knobs. Remove “C” clips and actuator knobs and retain for re-installation. Remove knob shafts and plastic washers.

*Note: Knobs are different. Mark them as left or right and reinstall in original location.*

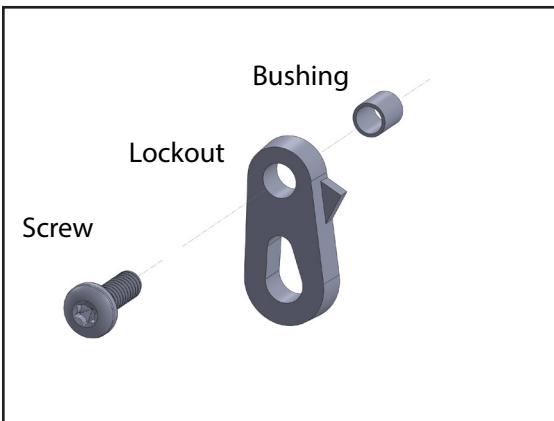

## Step 9

Remove lockout plate screw and retain short stainless bushing and lockout plate for re-installation. Install extended knob shafts and original plastic washers

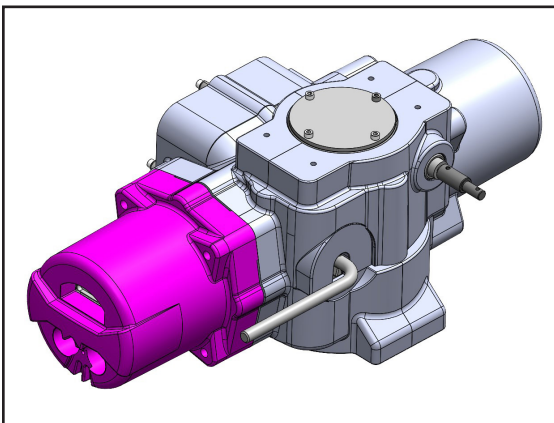

## Step 10

Install Electronics Cover (FRIQ1S-1702) and loosely bolt to upper and lower Gearcase Covers with (4) - M8 x 40 socket head cap screws.

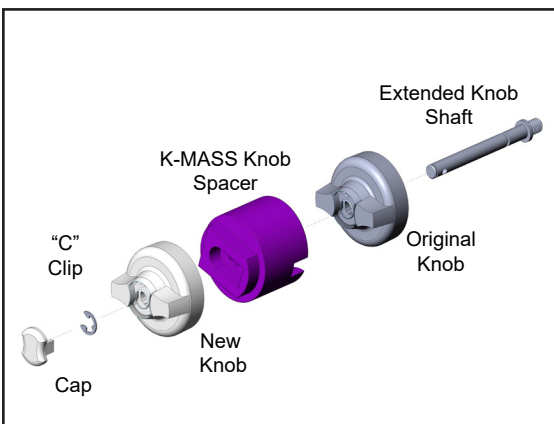

## Step 11

Install original plastic knobs, stacked with **K-MASS** knob spacers and new outer knobs (included) onto the Electronics Cover. Install “C” clips and center caps.



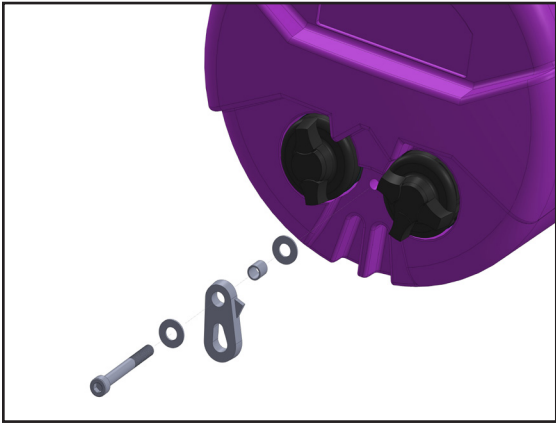

### Step 12

Install lockout plate with original bushing, washers and (1) - M6 x 60 screw to the K-MASS Electronics Cover. Apply Loctite Blue Thread Locker (included) to this bolt only (important).

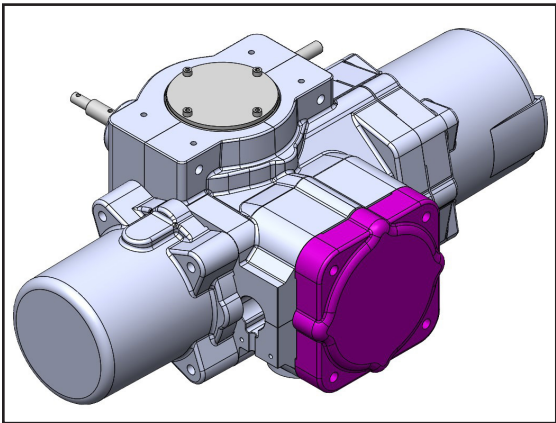

### Step 13

Install the Terminal Cover (FRIQ1S-1703) and loosely bolt to the Gearcase Covers with (4) - M8 x 30 socket head cap screws.

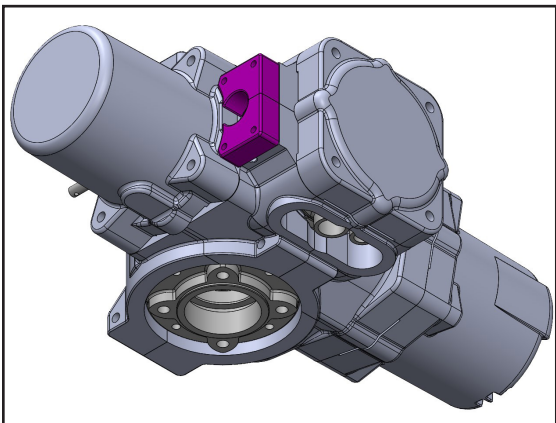

### Step 14

Install the Single Conduit Cover (FRIQ1S-1500 - Open) or (FRIQ1S-1501 - Closed) with (4) - M6 x 30 socket head cap screws.

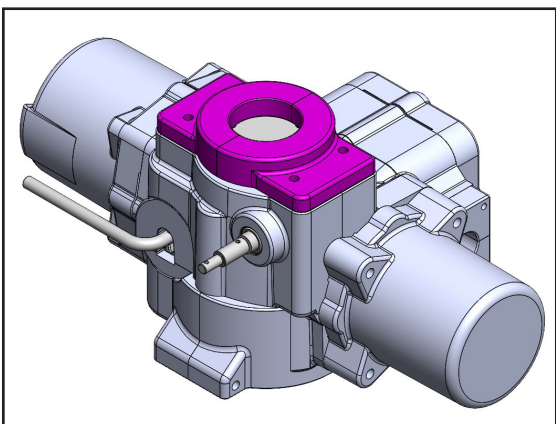

### Step 15

Install the Top Cover (FRIQ1S-1704 - Open) or (FRIQ1S-1705 - Closed) with (4) - M6 x 30 socket head cap screws.

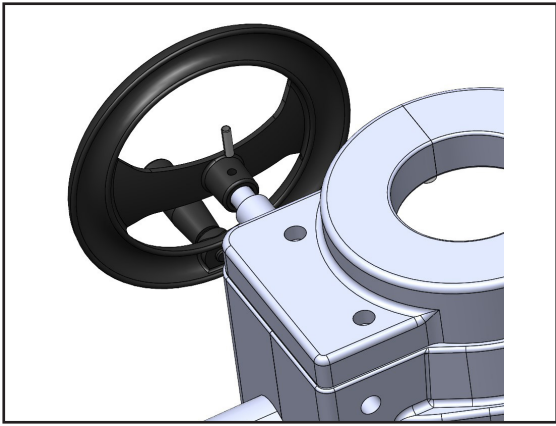

### **Step 16**

Install the handwheel on the Handwheel Shaft Extension using the split pin provided.

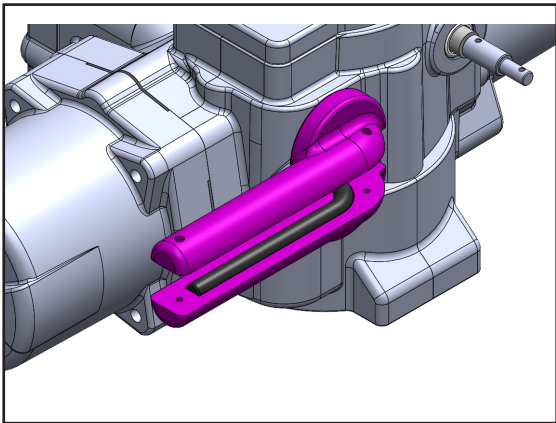

### **Step 17**

Install Declutch Lever Cover (FRIQ1S-1503) using (2) - M6 x 20 socket head cap screws.

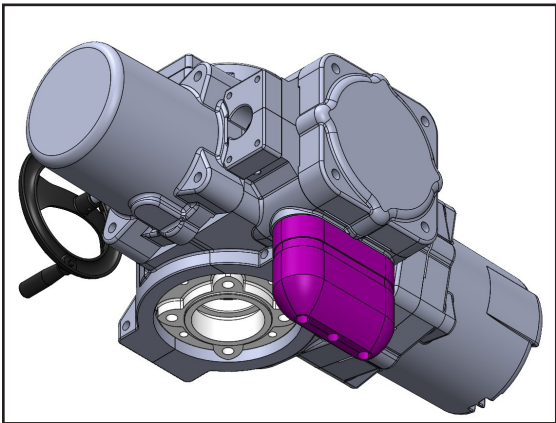

### **Step 18**

Install the triple conduit cover (KMCP1). Use internal clamps to attach to cables. Place second half and use band clamp to secure. Use 3M Caulk to fill unused holes in cover.

## ***IMPORTANT! FINAL STEPS***

1. Hand tighten all socket head bolts to 15 ft/ lbs. Do not over-torque.
2. Completely fill all bolt holes with 3M CP-25WB Fire Barrier Caulk (included).



Rotork IQ MK3 Size 1  
Installation Manual

*Safety is our top priority. Ensure all safety measures are adhered to in accordance with the site, location and regulatory standards. Assemble all fasteners loosely at first, and hand-tighten upon completion of assembly. Do NOT over torque any fasteners, doing so could damage the threaded insert or **K-MASS**.*

**Thermal Designs, Inc. - United States**  
5352 Prudence Street  
Houston, Texas 77045 USA  
Phone: +1 713-433-8110  
ussales@tdikmass.com

**Thermal Designs LTD UK - United Kingdom**  
The Broadway Market Lavington Devizes  
Wiltshire, England UK SN10 5RQ  
Phone: +44 (0) 1380 816079  
uksales@tdikmass.com

**Thermal Designs, Inc. - Canada**  
Unit 1, 5220 Duncan Ave  
Blackfalds, Alberta T0M 0J0  
Phone: +1 403-391-1578  
casales@tdikmass.com