

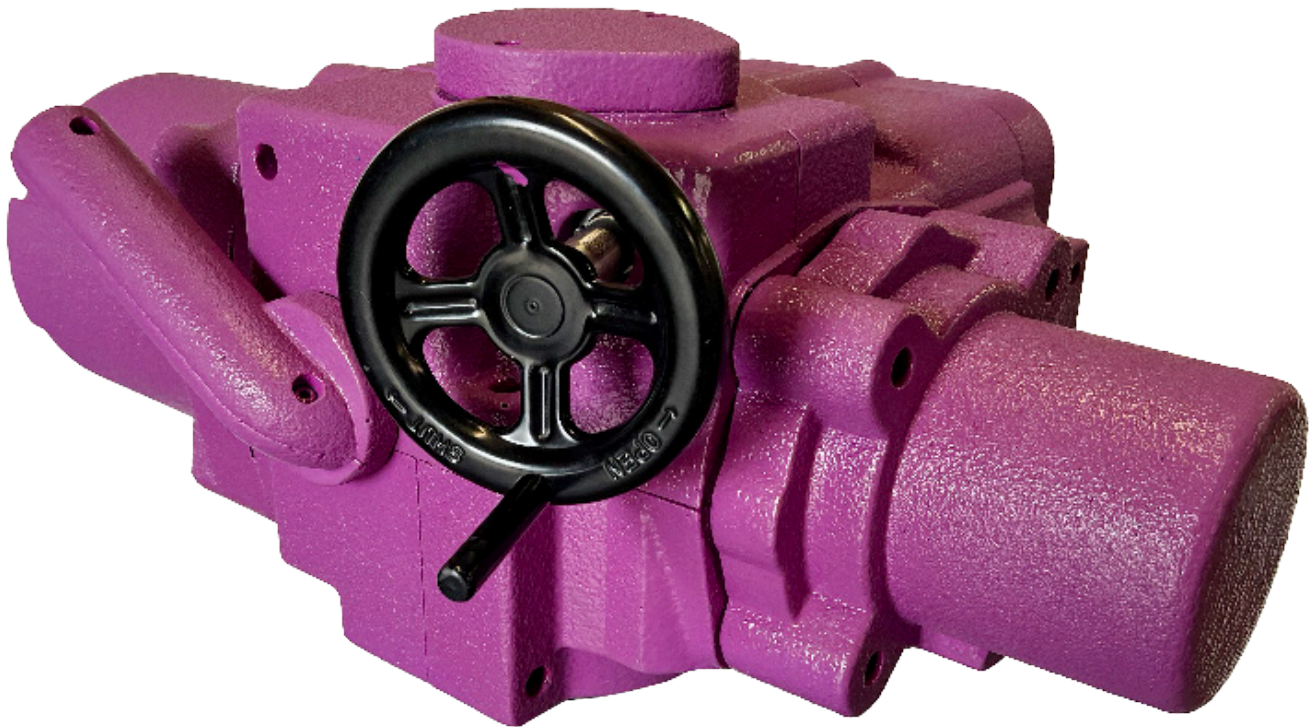

Field or Factory Installable **K-MASS**[®] Intumescent
Epoxy Covers for New or Installed Actuators



K-MASS *FI*
INSTALLATION MANUAL

ROTORK IQ MK3 SIZE 2
SIDE HANDWHEEL ACTUATORS

ROTORK IQ MK3 Size 2

Side Handwheel

TOOLS and HARDWARE REQUIRED

ITEM	QTY
5 mm Hex-Key Wrench	1
6 mm Hex-Key Wrench	1
Torx T-30 Tamper Resistant Wrench (included) - <i>to remove knob lockout tab</i>	1
1/8" Flat Screwdriver - <i>to remove small "C" Clip</i>	1
1/8" Drift Punch - <i>to remove and install knob shafts</i>	1
3/16" Drift Punch - <i>to remove and install roll pin in the handwheel</i>	1

FASTENERS and PARTS INCLUDED WITH KIT

SOCKET HEAD CAP SCREWS	
SIZE	QTY
M6-20	2
M6-30	4
M6-60	1
M8-30	8
M8-40	12

HANDWHEEL EXTENSION PARTS	
SIZE	QTY
Handwheel Shaft Extension	1
Split Pin 6mm x 25mm	1

KNOB PARTS INCLUDED WITH KIT

ITEM	QTY
Extended Knob Shaft and "C" Clips	2
Extended Knob Lock-Out Bolt (M6 x 60) and Washers 6mm Flat Washers (6mm)	2
OEM Plastic Knob	2
K-MASS Knob Spacers	2

ROTORK IQ MK3 Size 2

Side Handwheel

Modular Intumescent Epoxy Fireproofing that can be installed in about 30 minutes in the factory or in the field.

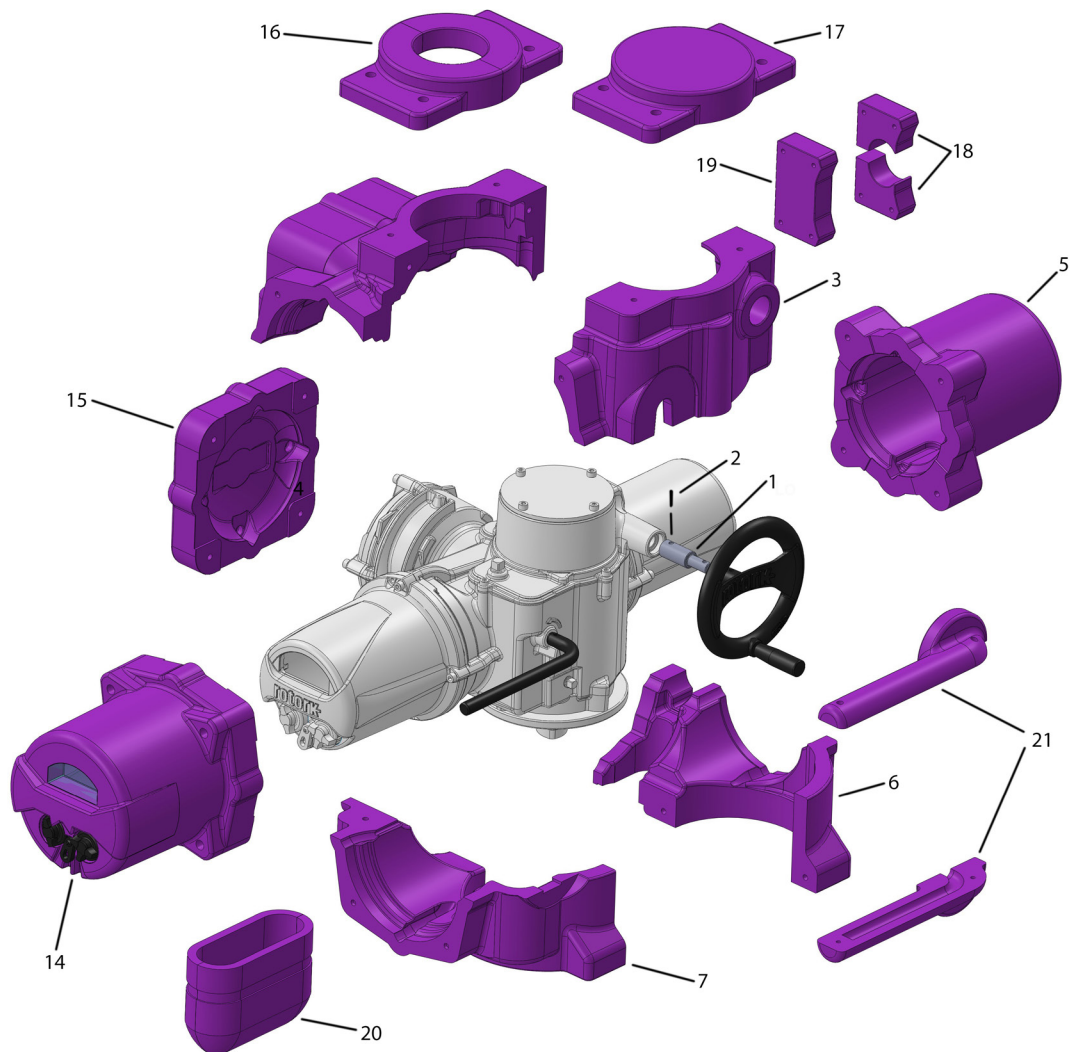

ROTORK IQ MK3 Size 2

Side Handwheel

K-MASS Knob Spacers and Knobs

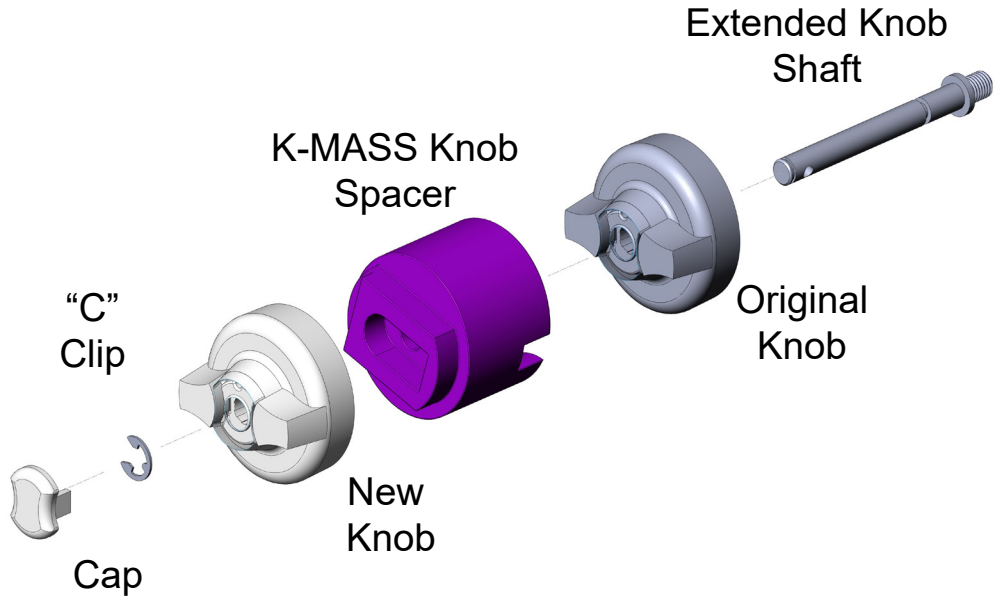

New Lockout Tab Assembly

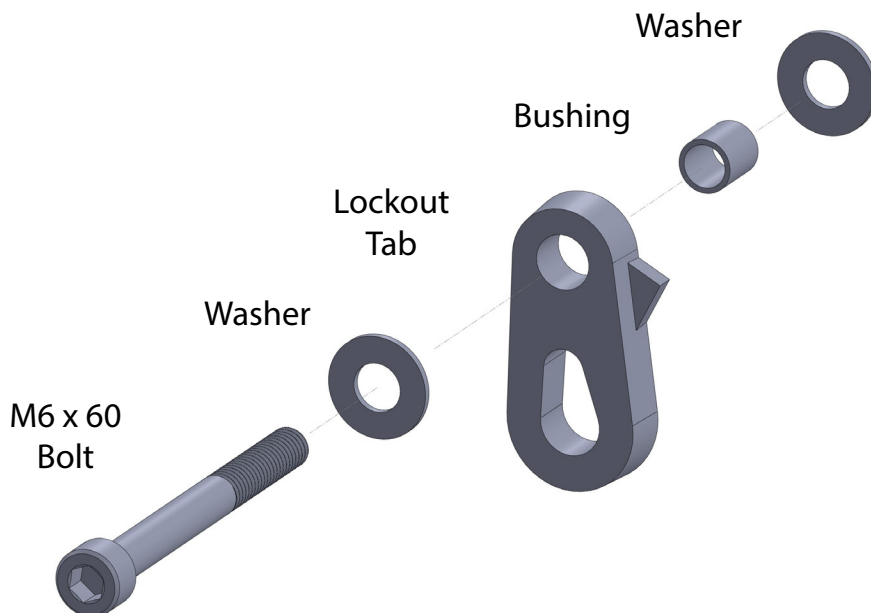

ROTORK IQ MK3 Size 2

Side Handwheel Actuator

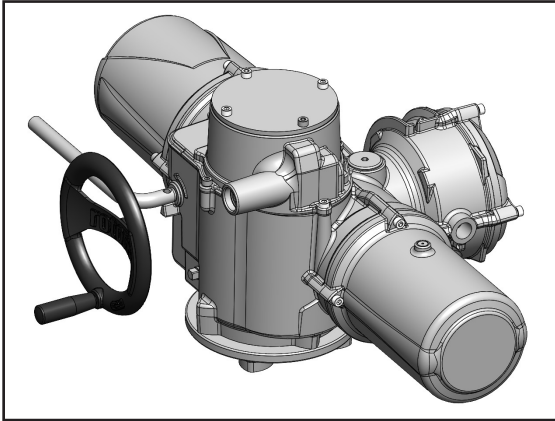

Step 1

Remove roll pin in the handwheel and remove handwheel.

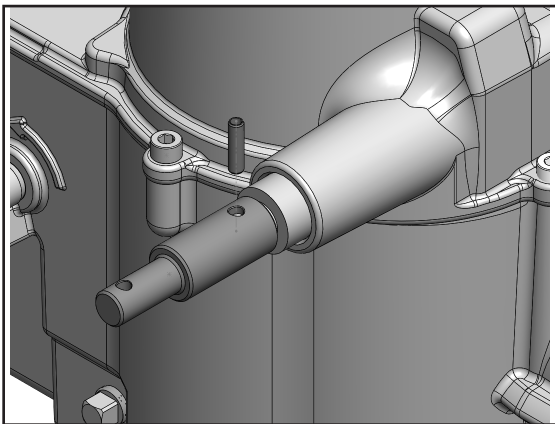

Step 2

Install Handwheel Shaft Extension (included FRIQ2S-2401) using Roll Pin (FRIQ2S-2402 included).

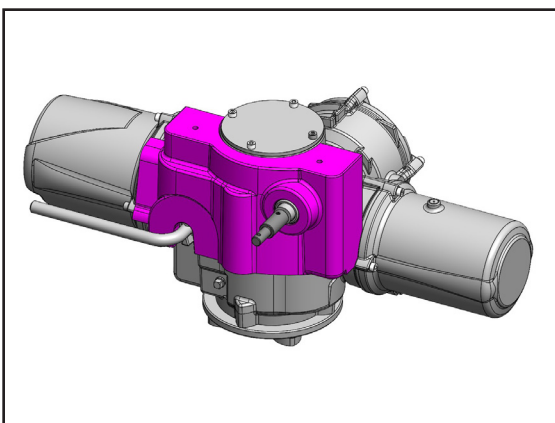

Step 3

Fit top handwheel/ declutch lever side Gearcase Cover (FRIQ2S-2100).

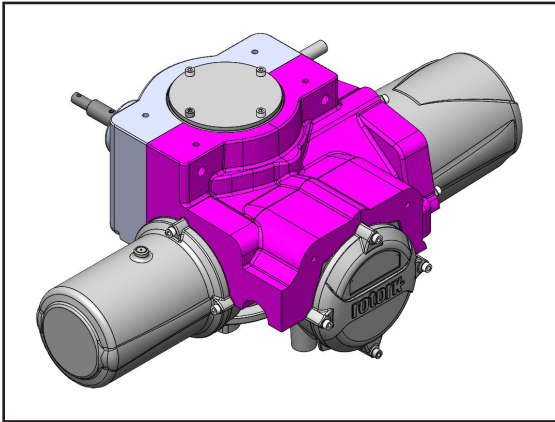

Step 4

Attach the terminal side of the Top Gearcase Cover (FRIQ2S-2101) next to motor with (2) - M8 x 40 socket head cap screws.

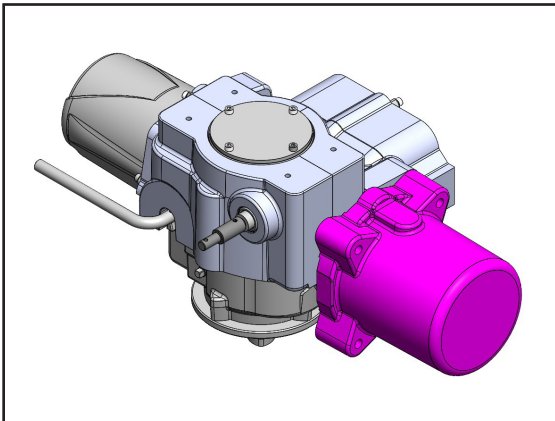

Step 5

Fit Motor Cover (FRIQ2S-2701) and loosely bolt to upper gearcase covers with (2) - M8 x 40 socket head cap screws.

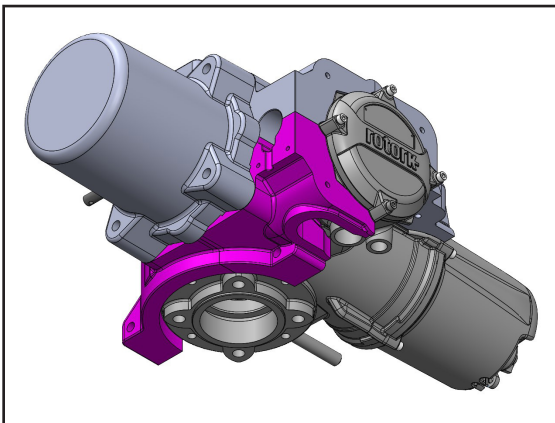

Step 6

Fit the motor side Lower Gearcase Cover (FRIQ2S-2102) and loosely bolt to Motor Cover using (2) - M8 x 40 socket head cap screws.

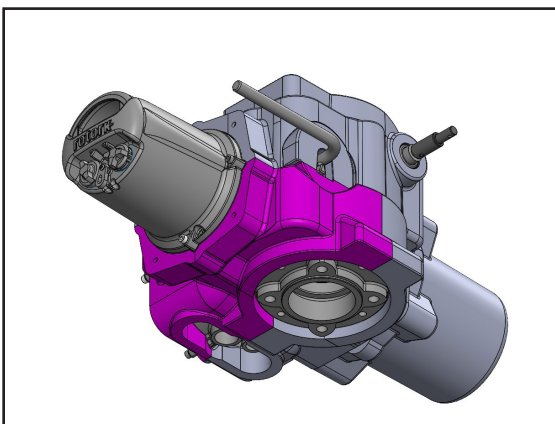

Step 7

Fit the lower electronics side Gearcase Cover (FRIQ2S-2103) and loosely bolt to the motor side Gearcase Cover using (2) - M8 x 40 socket head cap screws.

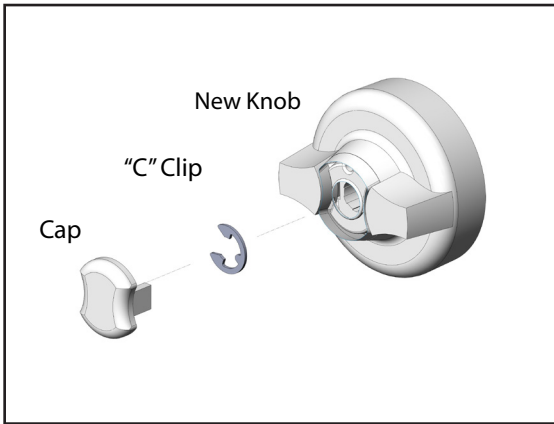

Step 8

Remove center caps from existing plastic knobs. Remove “C” clips and actuator knobs and retain for reinstallation. Remove knob shafts and plastic washers.

Note: Knobs are different. Mark them as left or right and reinstall in original location.

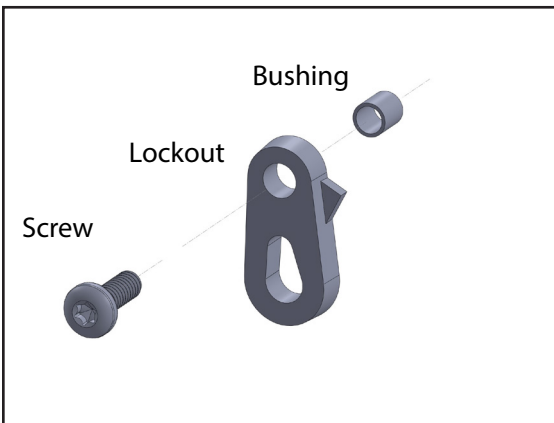

Step 9

Remove lockout plate screw and retain short stainless bushing and lockout plate for reinstallation. Install extended knob shafts and original plastic washers

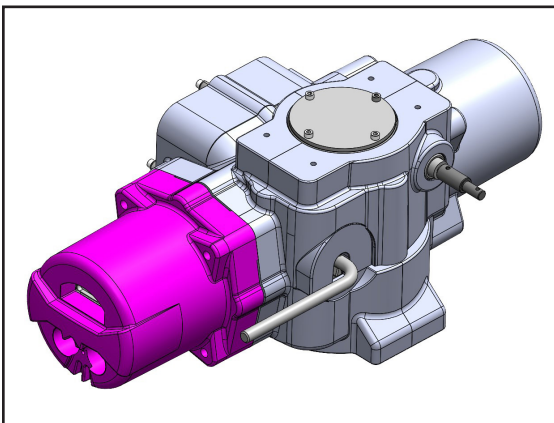

Step 10

Install Electronics Cover (FRIQ2S-2702) and loosely bolt to upper and lower Gear-case Covers with(4) - M8 x 40 socket head cap screws.

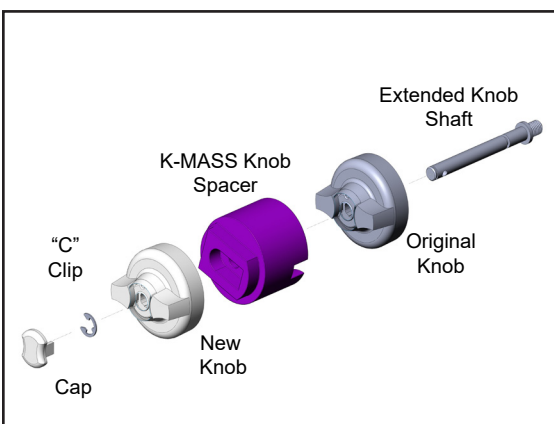

Step 11

Install original plastic knobs, stacked with **K-MASS** knob spacers and new outer knobs (included) onto the Electronics Cover. Install “C” clips and center caps.

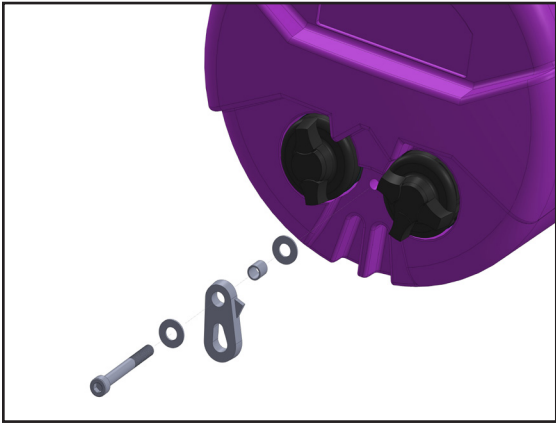

Step 12

Install lockout plate with original bushing, washers and (1) - M6 x 60 screw to the K-MASS Electronics Cover. Apply blue Loc-tite thread locker (included) to this bolt only (important).

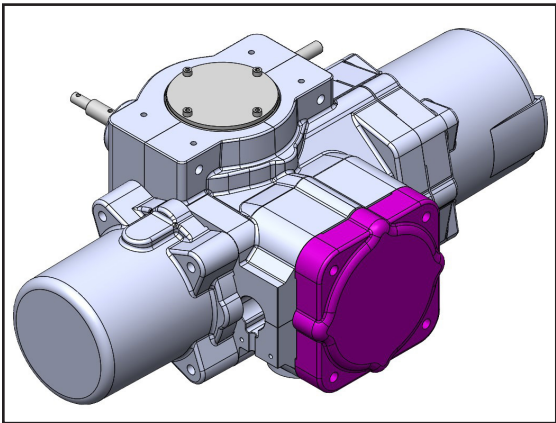

Step 13

Install the Terminal Cover (FRIQ2S-2703) and loosely bolt to the Gearcase Covers with (4) - M8 x 30 socket head cap screws.

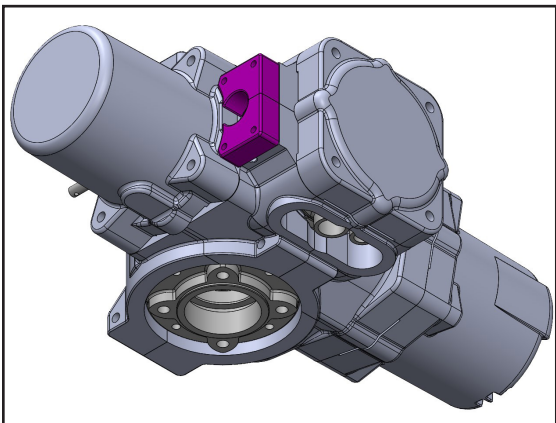

Step 14

Install the Single Conduit Cover (FRIQ2S-2500 - Open) or (FRIQ2S-2501 - Closed) with (4) - M6 x 30 socket head cap screws.

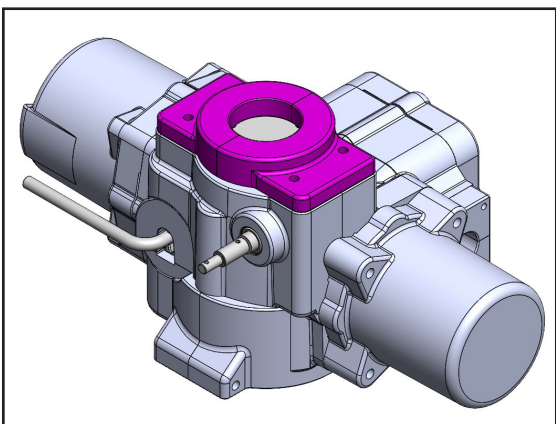

Step 15

Install the Top Cover (FRIQ2S-2704 - Open) or (FRIQ2S-2705 - Closed) with (4) - M6 x 30 socket head cap screws.

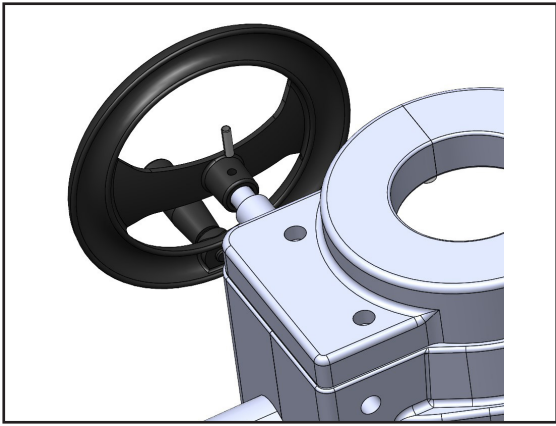

Step 16

Install the handwheel on the Handwheel Shaft Extension using the split pin provided.

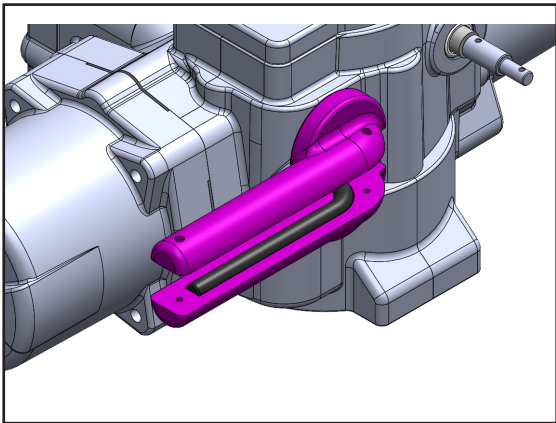

Step 17

Install Declutch Lever Cover (FRIQ2S-2503) using (2) - M6 x 20 socket head cap screws.

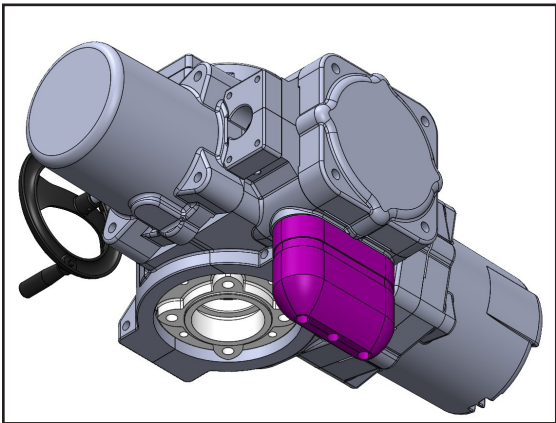

Step 18

Install the triple conduit cover (KMCP2). Use internal clamps to attach to cables. Place second half and use band clamp to secure. Use 3M Caulk to fill unused holes in cover.

IMPORTANT! FINAL STEPS

1. Hand tighten all socket head bolts to 15 ft/ lbs. Do not over-torque.
2. Completely fill all bolt holes with 3M CP-25WB Fire Barrier Caulk (included).



Rotork IQ MK3 Size 2
Installation Manual

*Safety is our top priority. Ensure all safety measures are adhered to in accordance with the site, location and regulatory standards. Assemble all fasteners loosely at first, and hand-tighten upon completion of assembly. Do NOT over torque any fasteners, doing so could damage the threaded insert or **K-MASS**.*

Thermal Designs, Inc. - United States
5352 Prudence Street
Houston, Texas 77045 USA
Phone: +1 713-433-8110
ussales@tdikmass.com

Thermal Designs LTD UK - United Kingdom
The Broadway Market Lavington Devizes
Wiltshire, England UK SN10 5RQ
Phone: +44 (0) 1380 816079
uksales@tdikmass.com

Thermal Designs, Inc. - Canada
Unit 1, 5220 Duncan Ave
Blackfalds, Alberta T0M 0J0
Phone: +1 403-391-1578
casales@tdikmass.com