



Field or Factory Installable **K-MASS**[®] Intumescent
Epoxy Covers for New or Installed Actuators



K-MASS *FI*
INSTALLATION MANUAL

**LIMITORQUE MXB-10
TOP HANDWHEEL ACTUATORS**

K-MASS FI

LIMITORQUE MXB-10

Top Handwheel

PART NUMBERS

Item	Description	Part Number	Qty
	K-MASS FI Kit for MXB-10	FQMXB-2000	
1	Top Gearcase Cover	FQMX-2101	1
2a	Handwheel Spacer with No Hole	FQMX-2701	1
2b	Handwheel Spacer with Hole	FQMX-2702	1
3	Lower Gearcase Cover - Motor Side	FQMX-2102	1
4	Lower Gearcase Cover - Electronics Cover Side	FQMX-2103	1
5a	Conduit Entry Cover - One Opening	FQMX-2703	1
5b	Conduit Entry Cover - Two Opening	FQMX-2704	1
6	Side Handwheel Cover	FQMX-2705	1
7	Thrust Base Cover (2 piece)	FQMX-2500	1
8	Terminal Cover	FQMX-2401	1
9a	Conduit Entry Cover - Motor Side	FQMX-2707	1
9b	Conduit Access Entry Cover - Motor Side	FQMX-2708	1
10	Motor Cover	FQMX-2201	1
11	Declutch Housing Ring	FQMX-2601	1
12	Declutch Housing Cover	FQMX-2603	1
13	Declutch Lever Cover	FQMX-2604	1
14	Center Knob Extension	FQMXB-2302	1
15	Side K-MASS Knob Spacers	FQMXB-2303	2
16	OEM Plastic Knob	FQMXB-2304	2
17	Electronics Cover	FQMXB-2301	1
18	Label Cap	FQMX-2710	1
	3M Fire Barrier Caulk (Tube)	FI-2001	1
	Box Primary/ Spare Fasteners	FI-2002	1
	USB Drive (Installation Manual and Video)	FI-2003	1
	Installation Manual	FI-2004	1

Limiterque MXB-10
Installation
Video



Limiterque MXB-10
Installation
Manual



K-MASS *FI*

LIMITORQUE MXB-10

Top Handwheel Hardware

TOOLS REQUIRED

5 mm Hex-Key Wrench	#1 Philips-head Screwdriver
6 mm Hex-Key Wrench	#2 Philips-head Screwdriver
8mm Drill Bit (Supplied)	10mm Wrench
Cordless Drill	

ALL FASTENERS INCLUDED WITH COMPLETE KIT

SOCKET HEAD CAP SCREWS	
SIZE	QTY (Spare)
M6-20	4 (1)
M6-30	5 (2)
M6-40	3 (1)
M6-45	8 (2)
M8-40	11 (3)
M8-60	4 (8)

PHILLIPS HEAD CAP SCREWS	
SIZE	QTY (Spare)
M2.5-1.2 x 16	2 (1)
M4-60	2 (1)
M5-40	1 (1)
M6-40 (with nut)	1 (1)

KNOB PARTS INCLUDED WITH COMPLETE KIT

ITEM	QTY
Center Knob Extension	1
Side K-MASS Knob Spacers	2

ITEM	QTY
OEM Plastic Knob	2

K-MASS FI

Modular Intumescent Epoxy Fireproofing that can be installed in about 30 minutes in the factory or in the field.

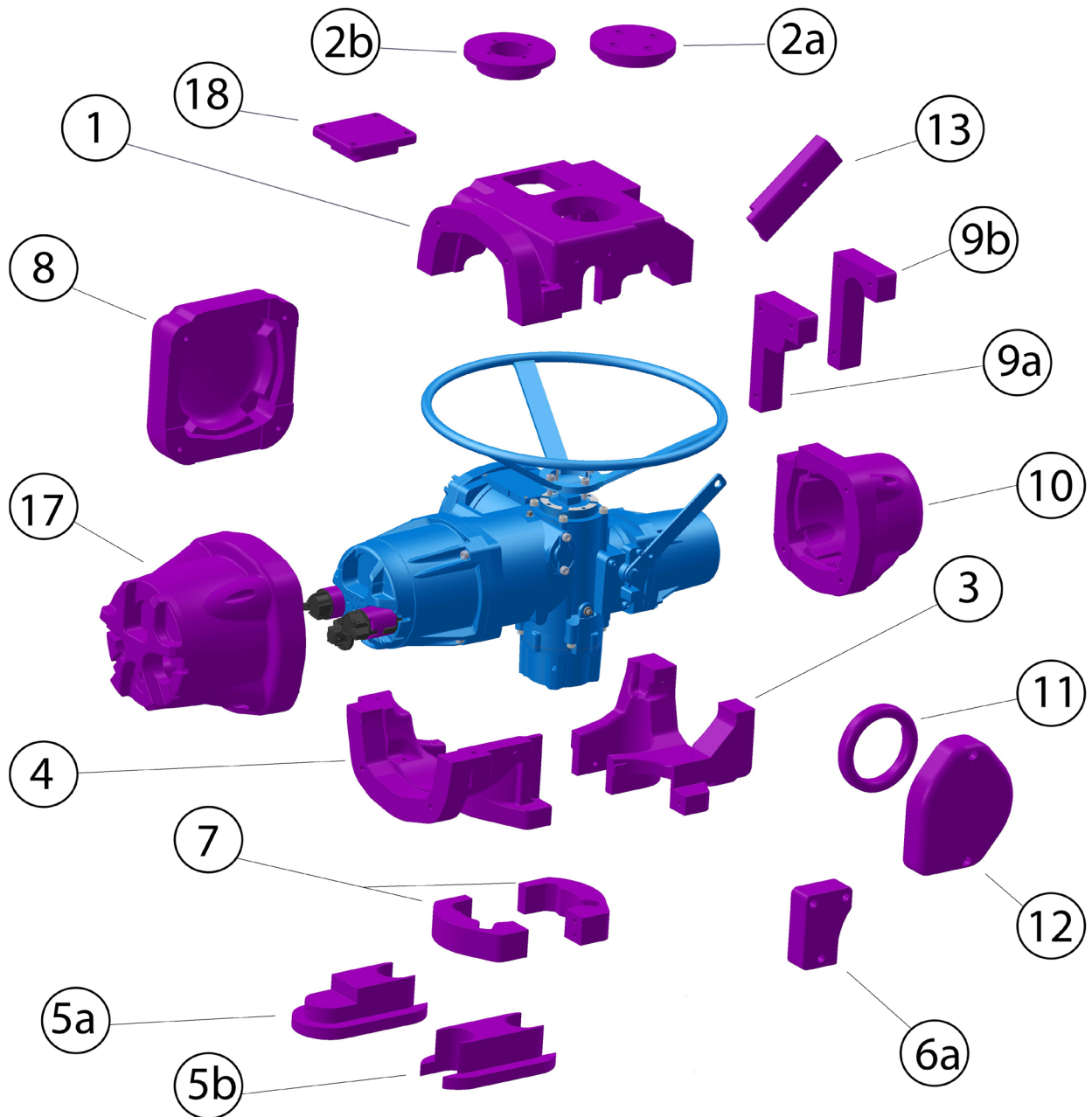

K-MASS FI

K-MASS Side Knob Spacers and Knobs

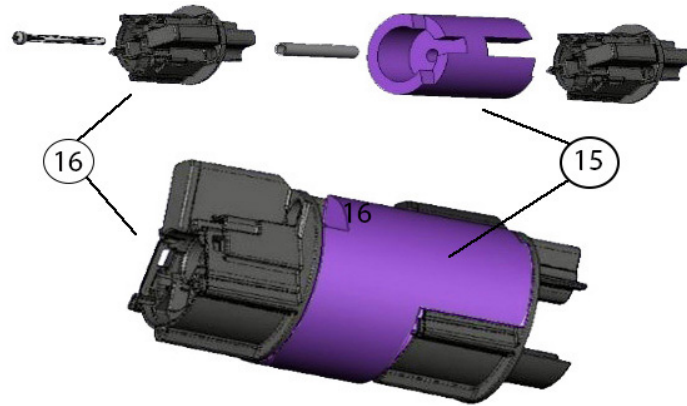

Center Knob Extension

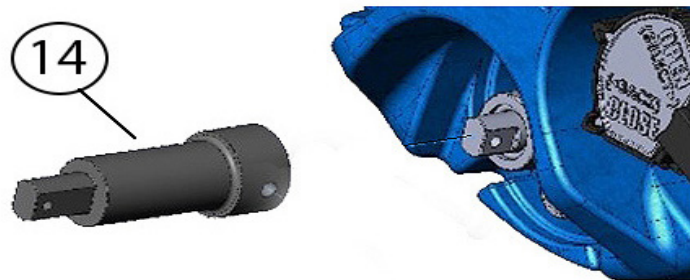

LIMITORQUE MXB-10

Top Handwheel Actuator



Step 1

Remove handwheel. Disconnect grounding/ earthing lug.

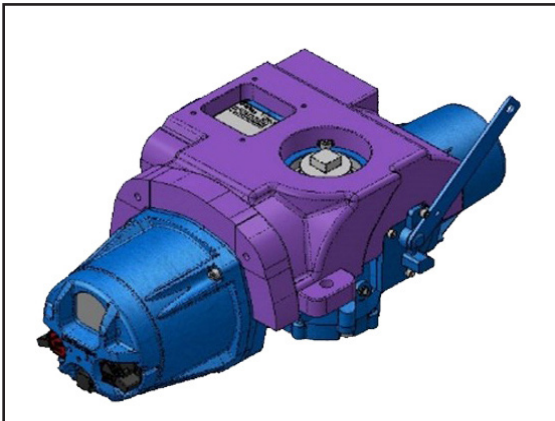

Step 2

Place top half of gearcase cover (FQMX-2101) on actuator body.

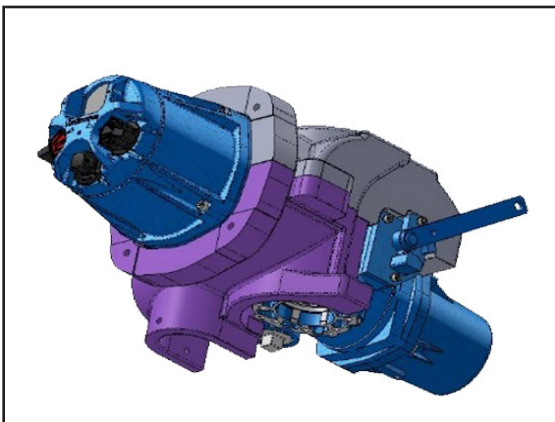

Step 3

Attach lower section of the gearcase cover next to actuator control cover (FQMX-2103) to top half of gearcase cover with (2) - M6 x 30 socket head cap screws.

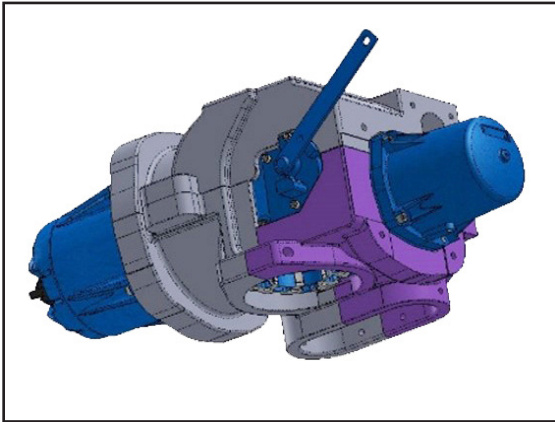

Step 4

Attach the second half of lower gearcase cover (FQMX-2102) next to motor with (1) - M6 x 45 socket head cap screw thru the boss below the declutch lever.

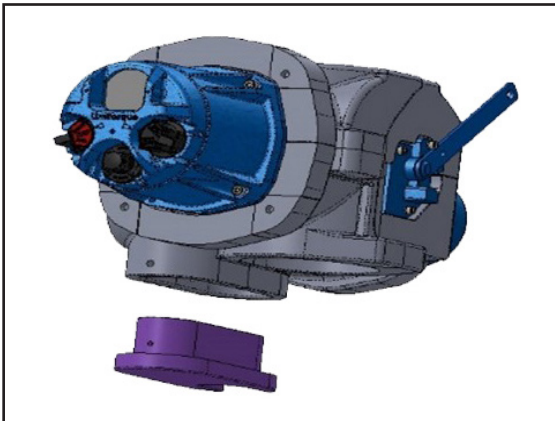

Step 5

Fit main conduit entry cover (FQMX-2703) to lower half of gearcase cover with (3) - M6 x 30 socket head cap screws.

(Fit the optional conduit entry plug, FQMX-2704 with two ports if required).

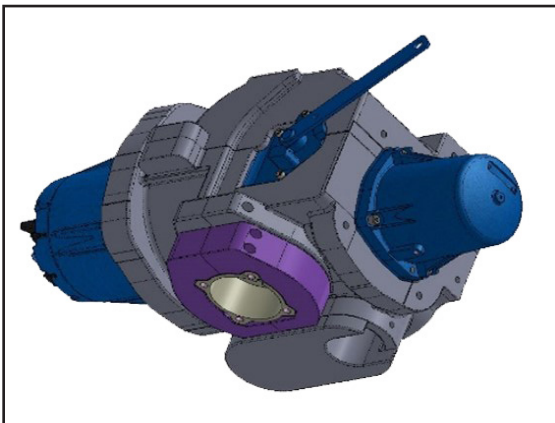

Step 6

If required, install the two-part thrust base cover (FQMX-2500) using (2) - M6 x 45 socket head cap screws.

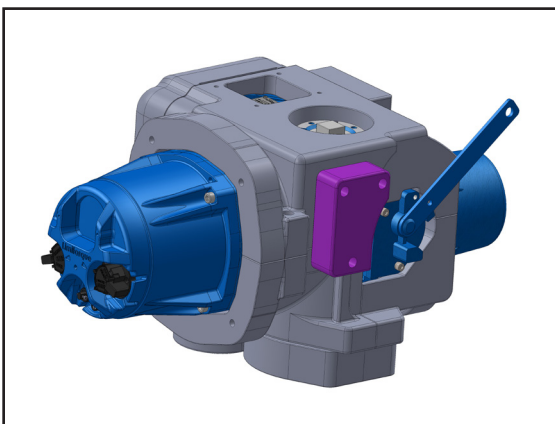

Step 7

Install the side handwheel cover (FQMX-27005) using (3) - M6 x 45 socket head cap screws.

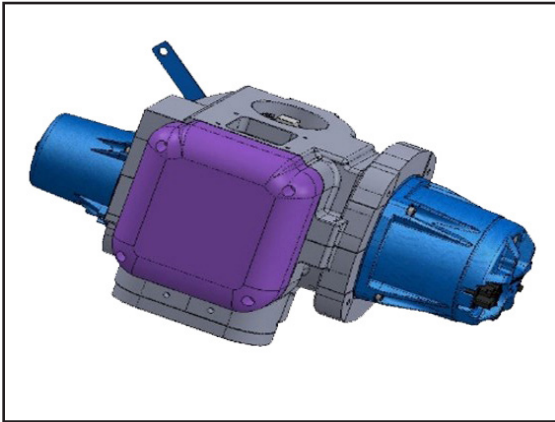

Step 8

Install terminal cover (FQMX-2401) with (4) - M8 x 40 socket head cap screws.

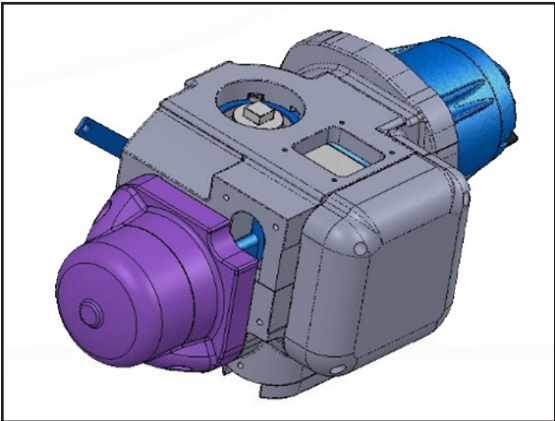

Step 9

Install the motor cover (FQMX-2201) with (3) - M8 x 40 socket head cap screws. Orient the motor cover such that the cutout corner is adjacent to the top conduit entry as shown.

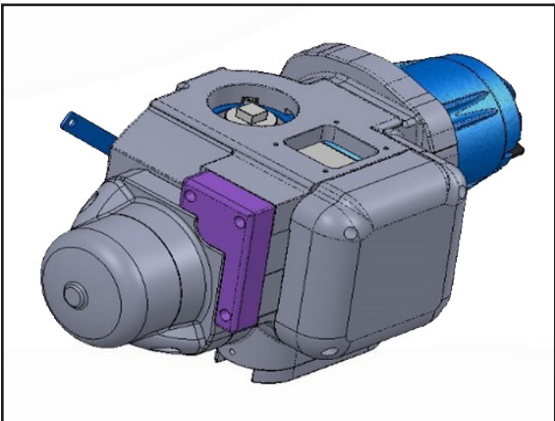

Step 10

Install the secondary conduit entry cover (FQMX-2707) next to the motor cover.

An optional part with “open” port is provided (FQMX-2708) if needed. Use (3) - M6 x 40 socket head cap screws.

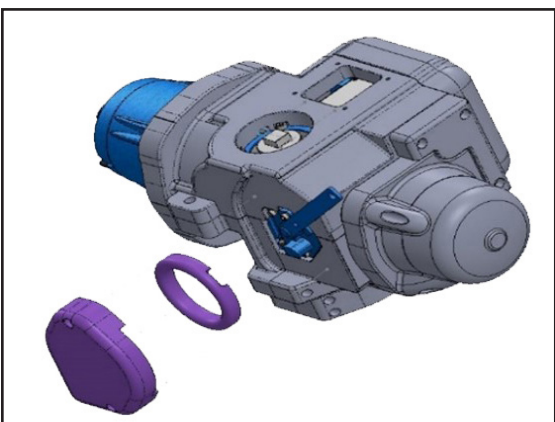

Step 11

Install the declutch housing ring (FQMX-2601) and cover (FQMX-2603) with (2) - M6 x 45 socket head cap screws. The slot on the ring goes towards actuator.

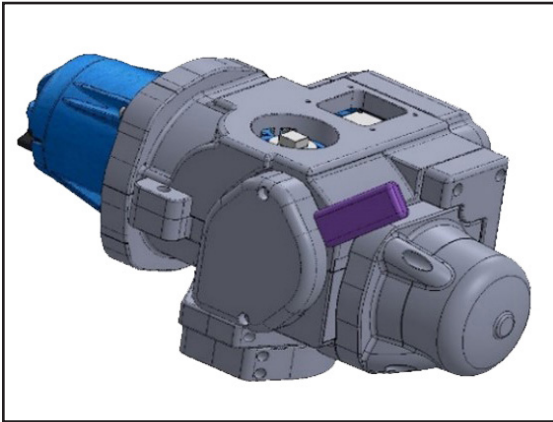

Step 12

Install the declutch lever cover (FQMX-2604) and use the supplied 8 mm drill bit to drill hole thru lever centered with hole in cover. Attach with (1) - M6 x 40 Phillips-head screw, washer, and locknut.

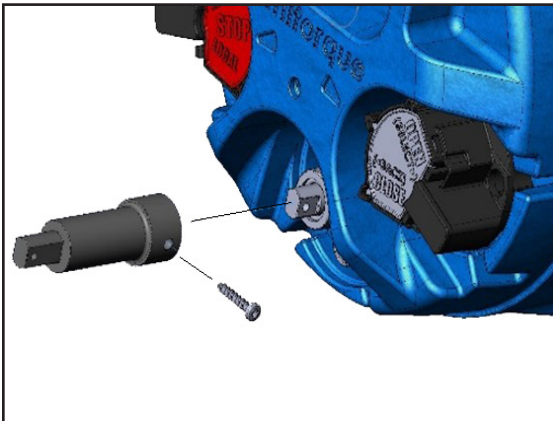

Step 13

Remove the center knob from the control cover and install the knob extension (FQMXB-2302) using (1) - M2.5-1.12 x 16 factory supplied Philips-head screw previously removed from center knob.

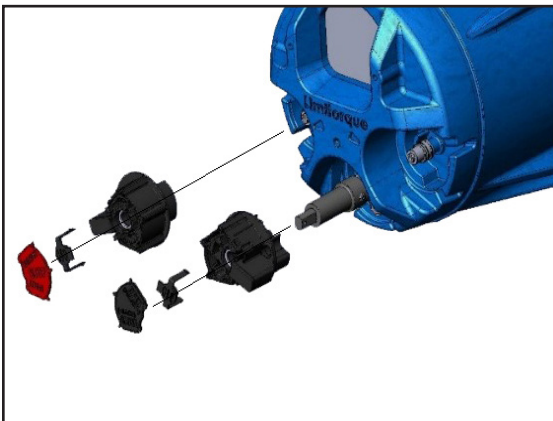

Step 14

Remove the two outer knobs from the control cover and note their position. Remove label caps, screw protector caps, O-rings, and thru bolts from the control cover.

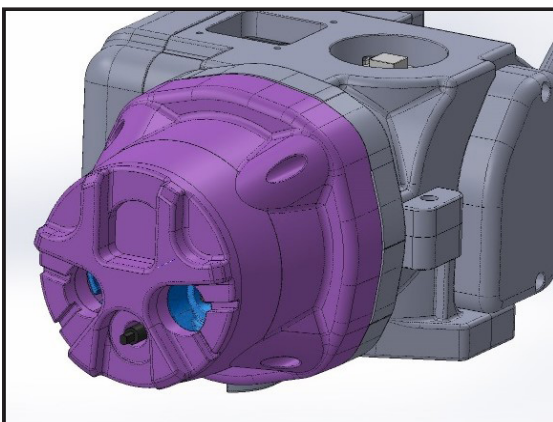

Step 15

Install the electronics cover (FQMXB-2301) with (4) - M8 x 40 socket head cap screws.

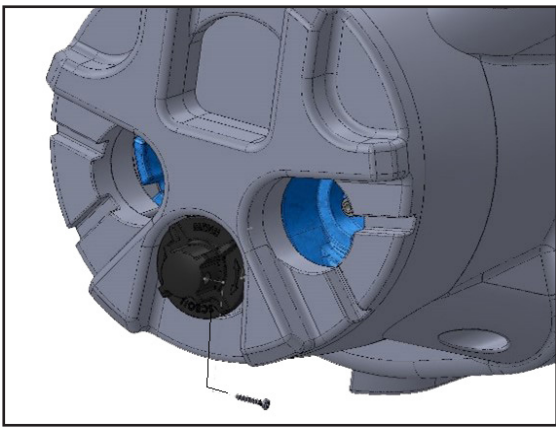

Step 16

Attach the center knob to the knob extension, using (1) - M2.5-1.12 x 16 screw.

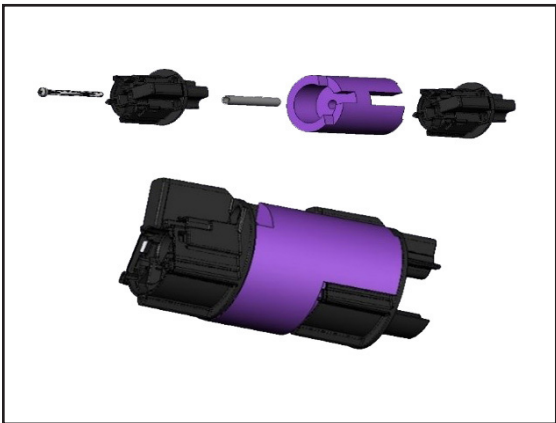

Step 17

Assemble the two selector knob stack-ups using the original inner knobs and (2) **K-MASS** knob spacers (FQMXB-2303), (2) stainless tubing, and (2) new selector knobs (FQMXB-2304). Press-fit together.

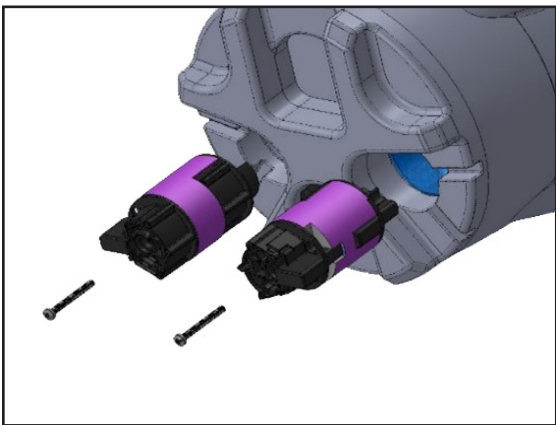

Step 18

Install both knob stack-up assemblies on the control cover in the correct locations with (2) - M4 - 60 mm Phillips-head machine screws.

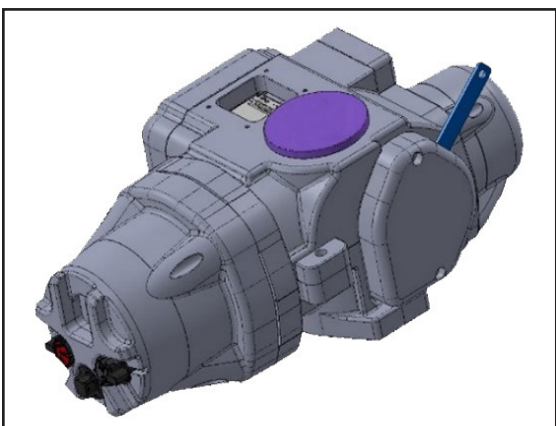

Step 19

Place the handwheel spacer with no center hole (FQMX-2701) on the top of the gear-case cover as shown.

Use spacer (FQMX-2702) with a center hole if required.

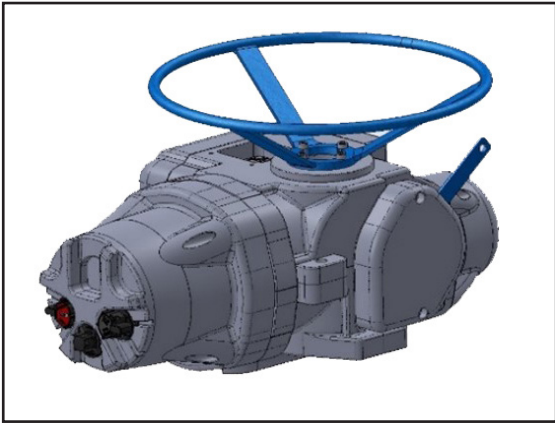

Step 20

Install the handwheel on top of the handwheel spacer (FQMX-2702) using (4) - M8 x 60 socket head cap screws.

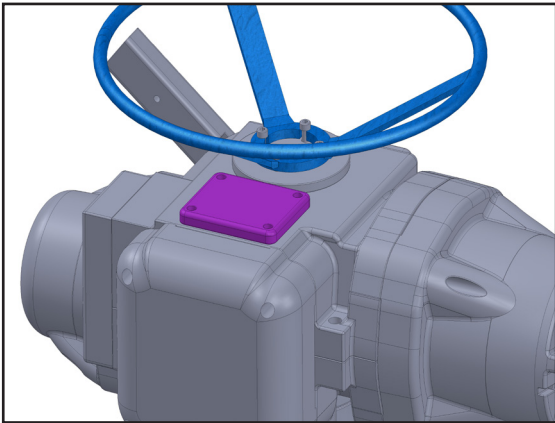

Step 21

Install the label cap (FQMX-2001) on the cover using (4) - M6 x 20 socket head cap screws.

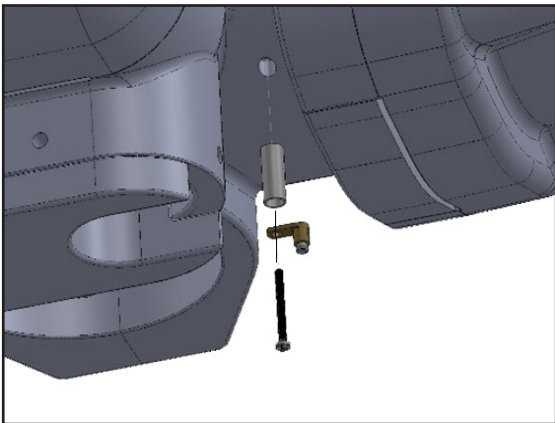

Step 22

Re-install grounding/ earthing lug using 10mm O.D. x 30mm stainless tube and M5 x 40 Phillips-head screw. Reconnect the grounding/ earthing wire.

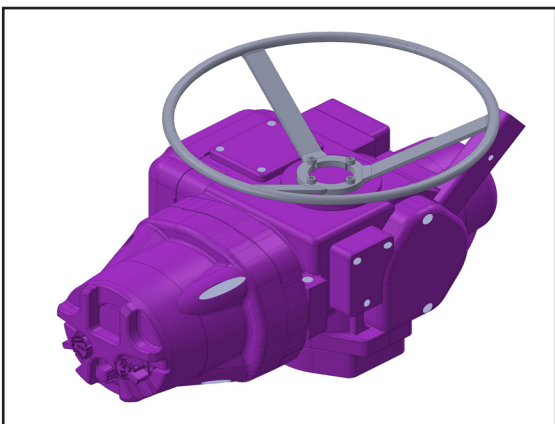

Step 23

Fit the De-Clutch Lever cover and tighten the two set screws. We strongly recommend filling all bolt holes with 3M™ Fire Barrier Caulk (FI-2001) included with the kit.



*Safety is our top priority. Ensure all safety measures are adhered to in accordance with the site, location and regulatory standards. Assemble all fasteners loosely at first, and hand-tighten upon completion of assembly. Do NOT over torque any fasteners, doing so could damage the threaded insert or **K-MASS**.*

Thermal Designs, Inc. - US
5352 Prudence Street
Houston, Texas 77045 USA
Phone: +1 713-433-8110
ussales@tdikmass.com

Thermal Designs LTD UK - UK
Broadway Market Lavington Devizes
Wiltshire, England UK SN10 5RQ
Phone: +44 (0) 1380 87079
uksales@tdikmass.com

Thermal Designs, Inc. - CA
Unit 1, 5220 Duncan Ave
Blackfalds, Alberta T0M 0J0
Phone: +1 403-391-1578
casales@tdikmass.com

**K-MASS Thermal Equipment
Middle East FZCO**
P.O. Box 7954, Jebel Ali Free Zone
Dubai, United Arab Emirates
Phone: +971 4 806-710
mesales@tdikmass.com